

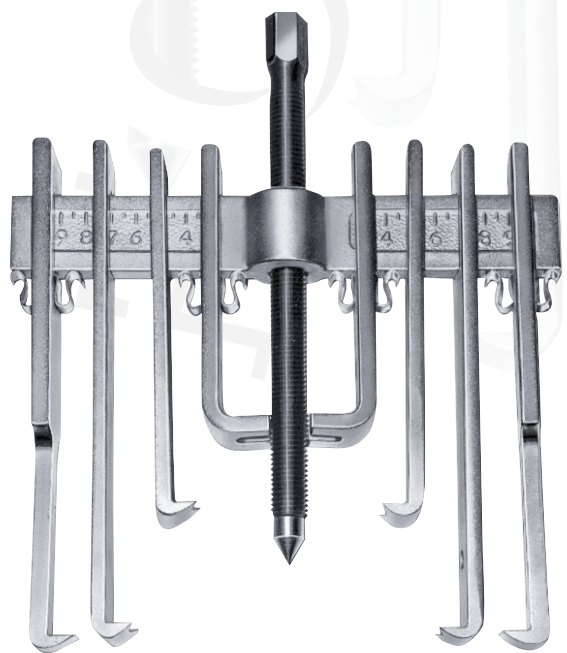

**Extractor Mecánico  
Exterior  
Serie 1800 y 1800T**

**Mechanical exterior puller  
1800 and 1800T Series**

Manual  
User's manual



**1800**



## 1. CARACTERÍSTICAS TÉCNICAS / TECHNICAL FEATURES

- Extractores de dos o tres patas reversibles / 2 and 3 arms puller reversible Ext and int
- Equipado con 4 agujeros de patas / Features 4 sets of arms
- Para exteriores e interiores / For exterior and interior
- Cuerpo Forjadas / Forged body
- Husillo con punto postizo a 90° giratorio / Spindle with swivle 90° point
- Las patas 32 tienen una ranura para poder tirar de tornillos / The arms 32 have a groove to pull with a screw

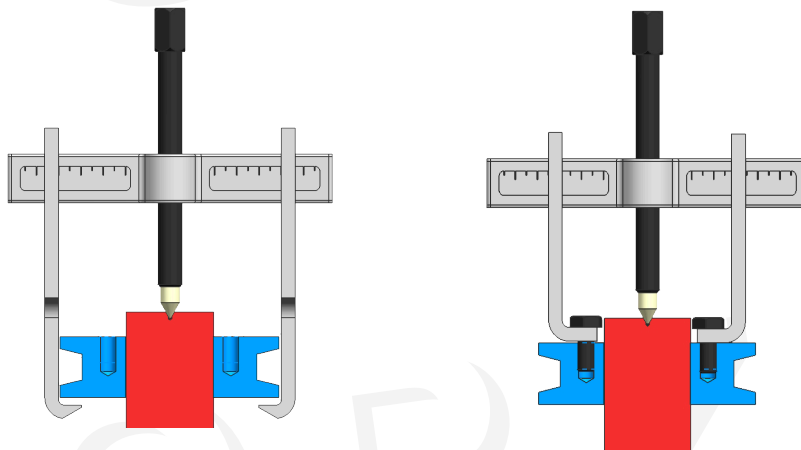

## 2. DIMENSIONES DEL EXTRACTOR / DIMENSIONS OF THE PULLER

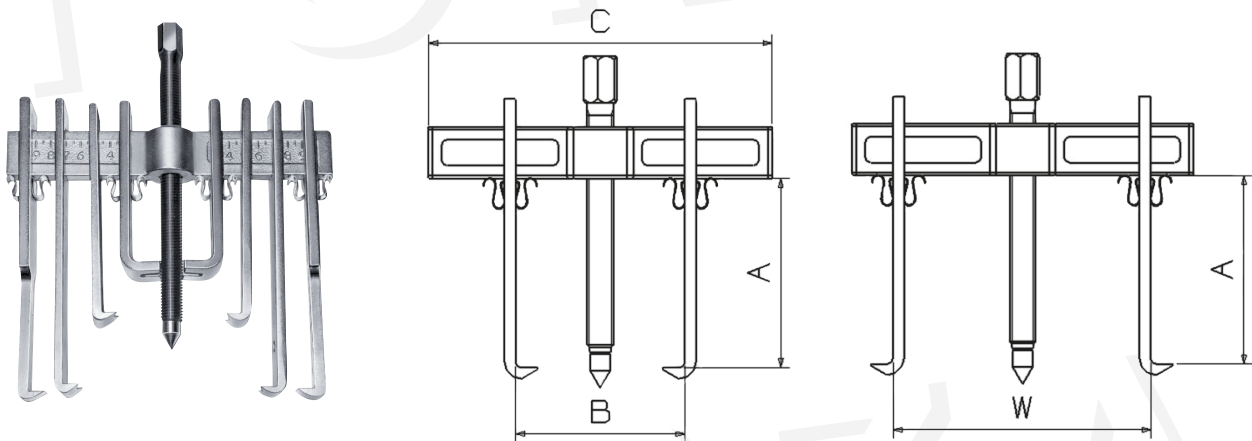

Ref.	A	B máx	B mín	C	W máx	W mín	Peso Weight	Patás incluidas Jaws included
1805	140	173	35	185	155	90	2,7	31 / 32 / 33 / 34
1810	182	250	35	280	260	105	6	31 / 32 / 33 / 34
1810-42	182	250	35	280	260	105	5	31 / 32 / 42

## Patatas / Arms

Los extractores se entregan con diversos juegos de patas.

La pata 44 es una pata con dos ventanas que puede sustituir a dos patas normales (33 y 34)

La medida de altura (A) de la tabla es con la pata más larga (31).

A continuación se detallan las medidas de las patas.

Pullers come with several sets of arms.

The arm 44 has two positions thus replacing two arms (33 y 34).

The height measurement A in the table is provided by the long arm 31.

Next are the sizes of the arms.

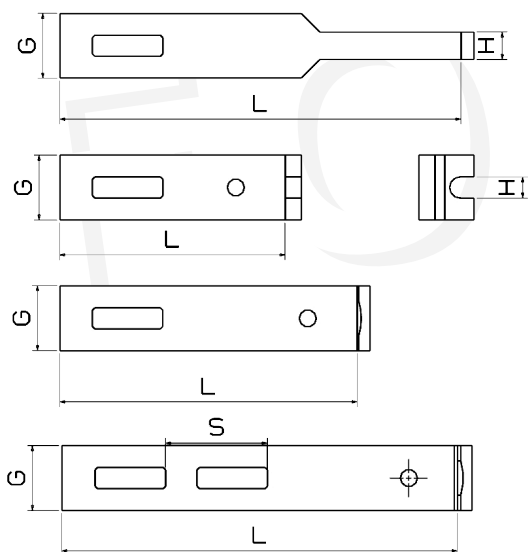
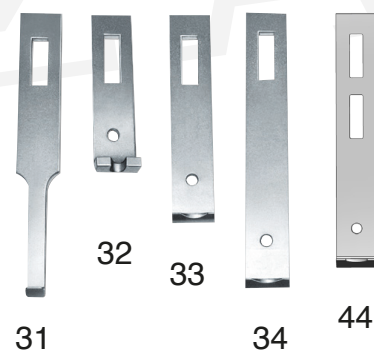

Pata / Arm	G	H	L	S
180531	30	12,5	182	-
180532	30	11	111	-
180533	30		145	-
180534	30		186	-
181031	40	17	245	-
181032	40	13	119	-
181033	40		183	-
181034	40		224	-
181044	40		224	63

Se pueden unir 2 patas para conseguir mayor altura  
You may combine two arms into another longer

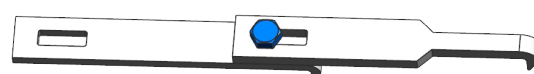
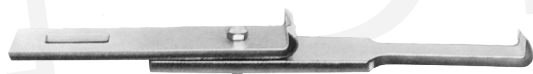

## 3 Patas / 3 Arms

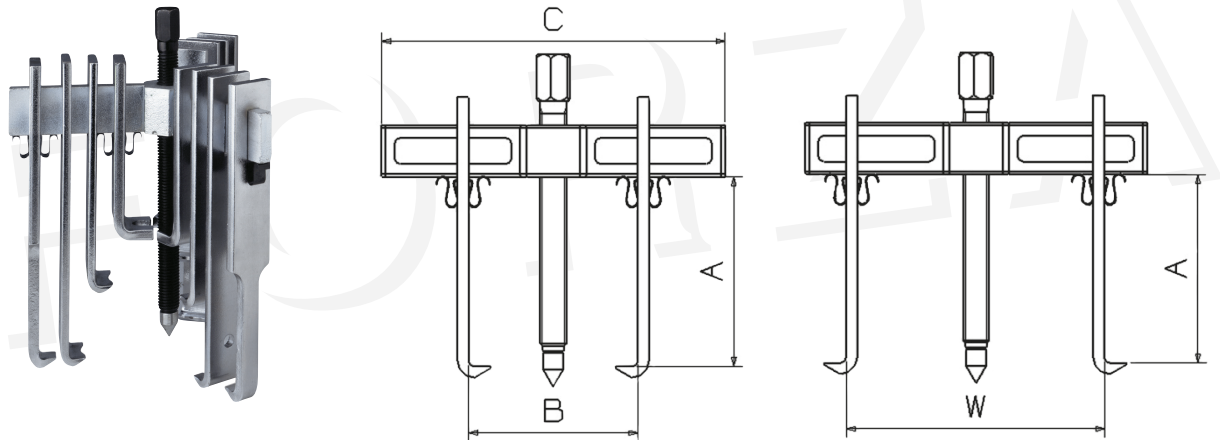

Ref.	A	B máx	B mín	C	W máx	W mín	Peso Weight	Patas incluidas Jaws included
1805T	140	173	35	185	155	90	3,7	31 / 32 / 33 / 34
1810T	182	250	35	280	260	105	8,5	31 / 32 / 33 / 34

### ■ 3. INSTRUCCIONES DE USO

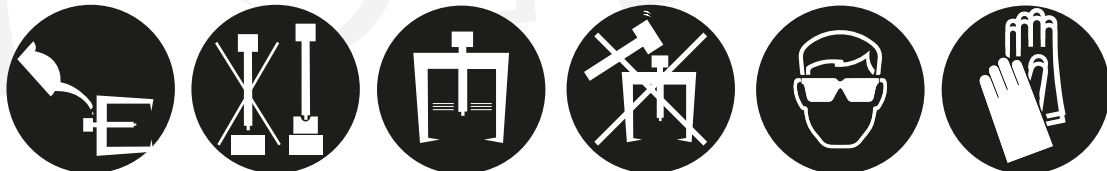

1. Asegúrese de que el husillo está perfectamente limpio y engrasado.
2. Compruebe que el eje esté punteado. Si no lo estuviera, colóquele un protector de punto.
3. Asegúrese que las patas estén perfectamente centradas.
4. Realice la fuerza de extracción girando el husillo. Nunca golpear el husillo.
5. No mantenga el husillo demasiado salido del cuerpo.
6. Utilice todos los equipos de protección individual (EPIs) necesarios
7. Las pata 32 están provistas de sendas ranuras para poder tirar de tornillos.

1. Make sure that the spindle is perfectly clean and greased.
2. Check that the shaft is punched, otherwise use a point protector.
3. See that arms are evenly spread.
4. Apply force by turning the spindle. Never strike the spindle.
5. Do not let the spindle protrude excessively from the body.
6. Wear all necessary safety equipments.
7. The arms 32 feature groove to pull with screws.

## ■ 4. APLICACIONES / APLICATIONS

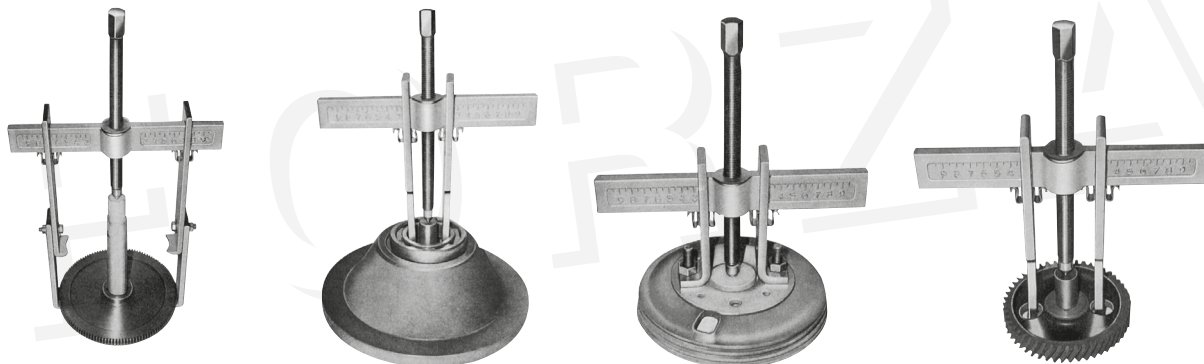

## ■ 5. PUNTO DEL HUSILLO / SPINDLE POINT

### Husillo con Punto postizo / Spindle with swivle 90° point

Estos husillos llevan un punto postizo rotativo a 90°. Si el eje no estuviera punteado deben usar un protector de punto para proteger el eje y el extractor de posibles daños.

In case the shaft were not punched it would be necessary to use a poin protector in order to prevent possible damage for the shaft and the puller.

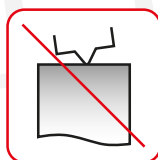

OK

Protector de punto / Protective point

## ■ 6. DESPIECE / SPARE PART

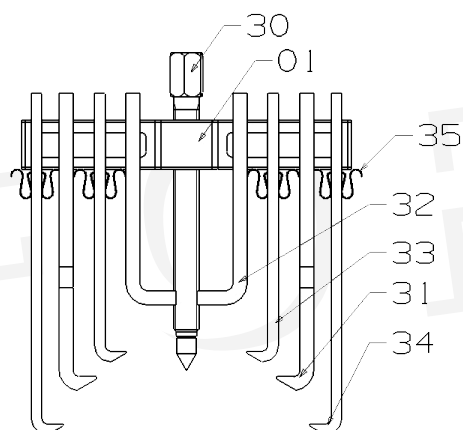

2 patas / 2 jaws

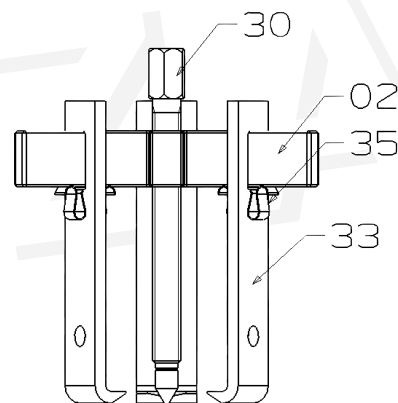

3 patas / 3 jaws

**Husillo / Spindle**

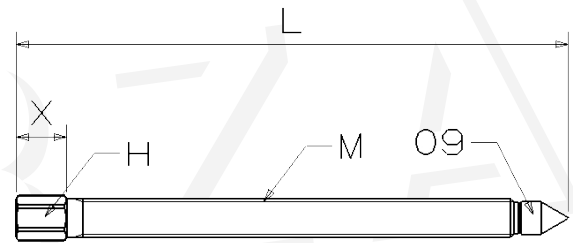

La referencia 180530 y 181030 incluyen el husillo completo, esto es el husillo (03) y el punto (09). Los puntos están montados con un remache a presión y es muy difícil cambiarlos por el usuario.

The references 180530 and 181030 include the complete spindle, It is the spindle 03 and the point 09. The points are riveted and difficult to change by the user.

Ref. husillo / Spindle ref.	Screw	L	X	H	09 Point
180530	9/16" UNC 12h	124	14	12	Postizo
181030	3/4" UNC 10h	321	25	22	Postizo

■ **7. PRESENTACIÓN EN ESTUCHES DE PLÁSTICO / PRESENTATION IN THE PLASTIC BOX**

En esta presentación se incluye un protector de punto.

In this set the point protector is included.



1810-C



1805-C



S.L. de Herramientas Especiales Forza  
C/ San Miguel de Atxa, 24  
01010 Vitoria  
[www.forza.es](http://www.forza.es)

---

