

Ref. **3150**

MACHO HELICOIDAL MÁQUINA MÉTRICA M. REFORZADO

Reinforced Shank Metric Machine Spiral Tap

Taraud Hélicoïdal Machine Métrique Queue Renforcée

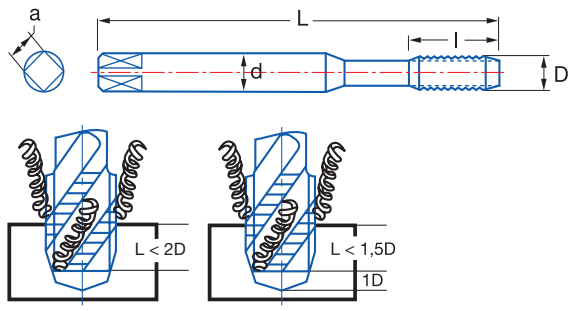

Material		Vc
Grupo	Sub.	5% Co
P	P.1	6-10
N	N.1	5-8
	N.3	15-35
	N.4	14-20

Vc= m/min.

M	P	L mm	l mm	d mm	a mm	Z	N° Art. 5% Co	€
M3	0,50	56	5	3,50	2,70	3	63050	12,66
M3,5	0,60	56	6	4,00	3,00	3	63053	18,62
M4	0,70	63	7	4,50	3,40	3	63056	12,66
M5	0,80	70	8	6,00	4,90	3	63059	12,08
M6	1,00	80	10	6,00	4,90	3	63062	13,27
M7	1,00	80	10	7,00	5,50	3	63065	20,67
M8	1,25	90	13	8,00	6,20	3	63071	15,16
M9	1,25	90	13	9,00	7,00	3	67882	25,84
M10	1,50	100	15	10,00	8,00	3	63083	17,98

M12, M14, M16: *Tol. 6G bajo demanda

*Tol. 6G upon request / *Tol. 6G sur demande