



ES	SPAIN
----	-------

# Diagram / Parts List

**HR2810T**

**ROTARY HAMMER 28MM**



(ES) HR2810T / ROTARY HAMMER 28MM

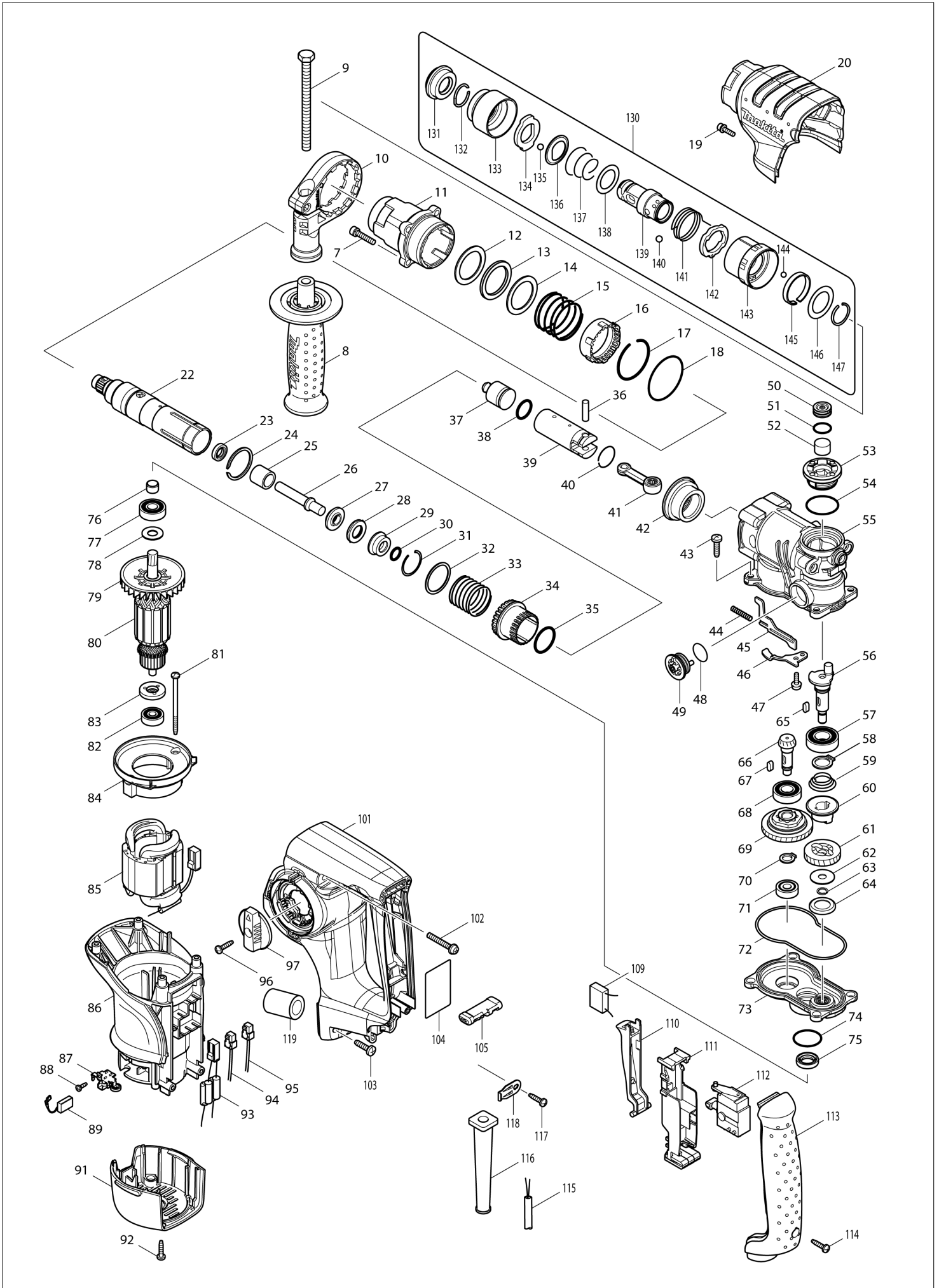

## HR2810T / ROTARY HAMMER 28MM

Item	Sub	Parts No.	Parts Description	Qty	I/C	E/C No.	Close No.	Remark
007		922241-7	HEX. SOCKET HEAD BOLT M5X25	4				
008		154842-5	GRIP 36 COMPLETE	1			83342	
	C10	931402-8	HEX. NUT M8	1			83342	
008-1		158057-6	GRIP 36 COMPLETE	1	O	83342		
	C10	931402-8	HEX. NUT M8	1		83342		
009		921919-9	HEX. BOLT M8X110	1				
010		419975-6	GRIP BASE 20	1				
011		158288-7	BARREL COMPLETE	1				
	C10	212403-8	NEEDLE BEARING 3012	1				
	C20	213965-9	OIL SEAL 25	1			86156	
	C21	213345-9	OIL SEAL 25	1	O	86156		
012		267354-0	FLAT WASHER 31	1				
013		262133-1	URETHANE RING 31	1				
014		267354-0	FLAT WASHER 31	1				
015		234020-4	COMPRESSION SPRING 37	1				
016		419986-1	LOCK SLEEVE	1				
017		233952-2	RING SPRING 41	1				
018		213620-3	O RING 46	1				
019		922128-3	HEX. SOCKET HEAD BOLT M4X16	1				
020		419984-5	CRANK HOUSING COVER	1				
022		158286-1	TOOL HOLDER GUIDE COMPLETE	1				
023		213076-0	OIL SEAL 9	1			86156	
023-1		213344-1	OIL SEAL 9	1	O	86156		
024		961140-8	RETAINING RING	1				
025		331769-8	SLEEVE 9	1				
026		324796-2	IMPACT BOLT	1				
027		324402-9	RING 10	1				
028		421955-0	CUSHION RING 13	1				
029		324216-6	O RING CASE	1				
030		213073-6	O RING 9	1				
031		233917-4	RING SPRING 28	1				
032		267105-1	FLAT WASHER 29	1				
033		234021-2	COMPRESSION SPRING 30	1				
034		331770-3	DRIVING SLEEVE	1				
035		213435-8	O RING 26	1				
036		256099-5	PIN 6	1				
037		324733-6	STRIKER	1				
038		213227-5	O RING 16	1				
039		331776-1	PISTON CYLINDER	1				
040		233954-8	RING SPRING 21	1				
041		158282-9	CONNECTING ROD COMPLETE	1				
	C10	212043-2	NEEDLE BEARING 810	1				
042		227532-4	SPIRAL BEVEL GEAR 31	1				
043		266420-0	TAPPING SCREW 5X20	4				
044		234019-9	COMPRESSION SPRING 4	1				
045		345814-3	LINK PLATE	1				
046		345815-1	GUIDE PLATE	1				
047		911118-1	PAN HEAD SCREW M4X12	1				
048		213262-3	O RING 18	1				
049		162256-4	LINK LEVER COMPLETE	1				
050		419988-7	FILTER CAP	1				
051		213218-6	O RING 16	1			DA223	
051-1		213A05-9	O-RING16	1	O	DA223		
052		443129-3	FILTER	1				
053		419987-9	CRANK CAP	1				
054		213406-5	O RING 30	1				
055		158289-5	CRANK HOUSING COMPLETE	1			84281	
055-1		158289-5	CRANK HOUSING COMPLETE	1	O	84281		
056		324793-8	CRANK SHAFT	1				
057		211232-6	BALL BEARING 6002LLU	1				
058		961055-9	RETAINING RING S-15	1				
059		233951-4	C. C. SPRING 16-26	1				
060		223167-9	CLUTCH	1				
061		226653-9	HELICAL GEAR 29	1				
062		267353-2	FLAT WASHER 8	1				

Interchange  
O : Yes  
X : No  
< : the new part can be substituted for the current.  
> : the current part can be substituted for the new.  
S : Interchangeable as a set.

ES

SPAIN

## HR2810T / ROTARY HAMMER 28MM

Item	Sub	Parts No.	Parts Description	Qty	I/C	E/C No.	Close No.	Remark
063		961034-7	RETAINING RING	1				
064		345818-5	CUP WASHER 16	1				
065		254239-9	KEY 4	2				
066		227524-3	SPIRAL BEVEL GEAR 9	1				
067		254239-9	KEY 4	1				
068		210105-0	BALL BEARING 6001LLU	1				
069		125386-2	TORQUE LIMITER ASS'Y	1				
070		961006-2	RETAINING RING S-10	1				
071		210024-0	BALL BEARING 608LLU	1				
072		424028-8	SEAL RING	1				
073		158287-9	GEAR HOUSING COMPLETE	1				
074		213445-5	O-RING 26	1				
075		213133-4	OIL SEAL 12	1			A7977	
075-1		213678-2	OIL SEAL 12	1	O	A7977		
076		331775-3	SLEEVE 10	1				
077		210054-1	BALL BEARING 6000LLU	1				
078		253171-4	FLAT WASHER 10	1				
079		240095-3	FAN 64	1				
080		515294-9	ARMATURE ASS'Y 240V	1				
	D10		INC. 79,82,83					
081		266325-4	TAPPING SCREW 4X70	2				
082		210023-2	BALL BEARING 627DDW	1				
083		681656-4	INSULATION WASHER	1				
084		419989-5	BUFFLE PLATE	1				
085		526584-5	FIELD ASS'Y 240V	1				
	C10	654283-0	CONTACT	2				
	C20	686044-0	CONNECTOR HOUSING	1				
086		419981-1	MOTOR HOUSING	1				
087		643766-5	BRUSH HOLDER	2				
088		266421-8	TAPPING SCREW 3X10	2				
089		194074-2	CARBON BRUSH CB-325	1				
091		419983-7	REAR COVER	1				
092		266326-2	TAPPING SCREW 4X18	2				
093		638568-2	CHOKE COIL UNIT	1				
094		638567-4	LEAD UNIT	1				
095		638566-6	LEAD UNIT	1				
096		266326-2	TAPPING SCREW 4X18	1				
097		158284-5	CHANGE LEVER COMPLETE	1				
101		419976-4	HANDLE	1				
102		911258-5	PAN HEAD SCREW M5X35	2				
103		266420-0	TAPPING SCREW 5X20	2				
104		863921-5	HR2810T NAME PLATE	1				
105		419992-6	F/R CHANGE LEVER	1				
109		645200-1	NOISE SUPPRESSOR	1				
110		419990-0	SWITCH LEVER	1				
111		158281-1	SWITCH HOLDER COMPLETE	1				
112		650591-7	SWITCH	1				
113		419980-3	HANDLE COVER	1				
114		266326-2	TAPPING SCREW 4X18	1				
115		665890-4	POWER SUPPLY CORD 1.0-2-4.0	1				
116		682573-1	CORD GUARD 10	1				
117		266326-2	TAPPING SCREW 4X18	1				
118		687169-3	STRAIN RELIEF	1				
119		685722-9	SPONGE	1				
130		194080-7	TOOL HOLDER SET	1				
	D10		INC. 131-147					
131		286263-4	CAP 35	1				
132		233940-9	RING SPRING 19	1				
133		418217-5	CHUCK COVER	1				
134		345333-9	STOPPER	1				
135		216022-2	STEEL BALL 7.0	1				
136		345187-4	GUIDE WASHER	1				
137		233916-6	CONICAL COMP. SPRING 21-29	1				
138		267279-8	FLAT WASHER 21	1				
139		324355-2	TOOL HOLDER	1				

Interchange

O : Yes

X : No

&lt; : the new part can be substituted for the current.

&gt; : the current part can be substituted for the new.

S : Interchangeable as a set.

